

## Transformer Voltage Monitoring Board

for 3 x 100/57 V AC

for use on utility billing meters

### EPW 2Ü/4K



#### Performance data ...

- Monitoring for undervoltage and “Power ON”
- 19" plug-in board 100 x 160 mm with 32-pin D connector
- 7 module wide front panel with LED display
- Signal via floating two-way relay contacts
- Potential isolation for all circuits

**Saves the need for check-back lines from switches**

## Technical description:

The monitoring board provides 2 basic functions:

1. Monitoring of the presence of the mains supply voltage, whereby at least one phase must lie above 50%  $U_N$ . Relay K1 is energised and the LED "Power ON" is lit.
2. Monitoring to detect a fall below 85 %  $U_N$  in one or more of the phase voltages. If no fault is present, relay K2 is energised and the green LED "Undervoltage" is lit.

To prevent momentary error signals in the case of mains switching operations, the board observes response delays of approx. 1 second for "Power ON" and approx. 3 seconds for "Undervoltage".

The times and switching thresholds can be changed via setting potentiometers if required.

An auxiliary supply of 24 V DC or up to 230 V AC is required for the module itself.

The two relay contacts are usually connected in series, so that a signal is generated if the mains supply is switched on but an undervoltage is detected.

## Technical specifications:

Monitored voltage:	3 x 100/57 V AC 50/60 Hz
Auxiliary supply	24 V DC, 24 ... 230 V AC 50/60 Hz
Power consumption	approx. 2.5 VA
Basic settings:	
Undervoltage	85/90% $U_N$
Response delay	approx. 1 sec. (max. 6 sec.)
Power ON	45/50% $U_N$
Response delay	approx. 3 sec. (max. 30 sec.)
Setting accuracy	
Voltages	$\pm 2\%$
Times	$\pm 5\%$
Contact rating	24 V DC 2 A; up to 110 V DC 0.3 A; 220 V DC 0.15 A; up to 250 V AC 4 A;
Insulation voltages	
Monitoring input/aux. supply/output contacts	4 kV <sub>eff</sub>
Impulse voltages at inputs	5 kV 1.2/50 $\mu$ s

For other values, please enquire.

Errors excepted. Subject to technical modifications.

**EES Elektra Elektronik GmbH & Co Störcontroller KG**  
 Hummelbühl 7-9 · D-71522 Backnang/Germany · Postfach 12 40 · D-71502 Backnang  
 Telephone: +49(0)7191/182-0 · Fax: +49-(0)7191/182-200 · E-mail: info@ees-online.de  
 Internet: <http://www.ees-online.de>

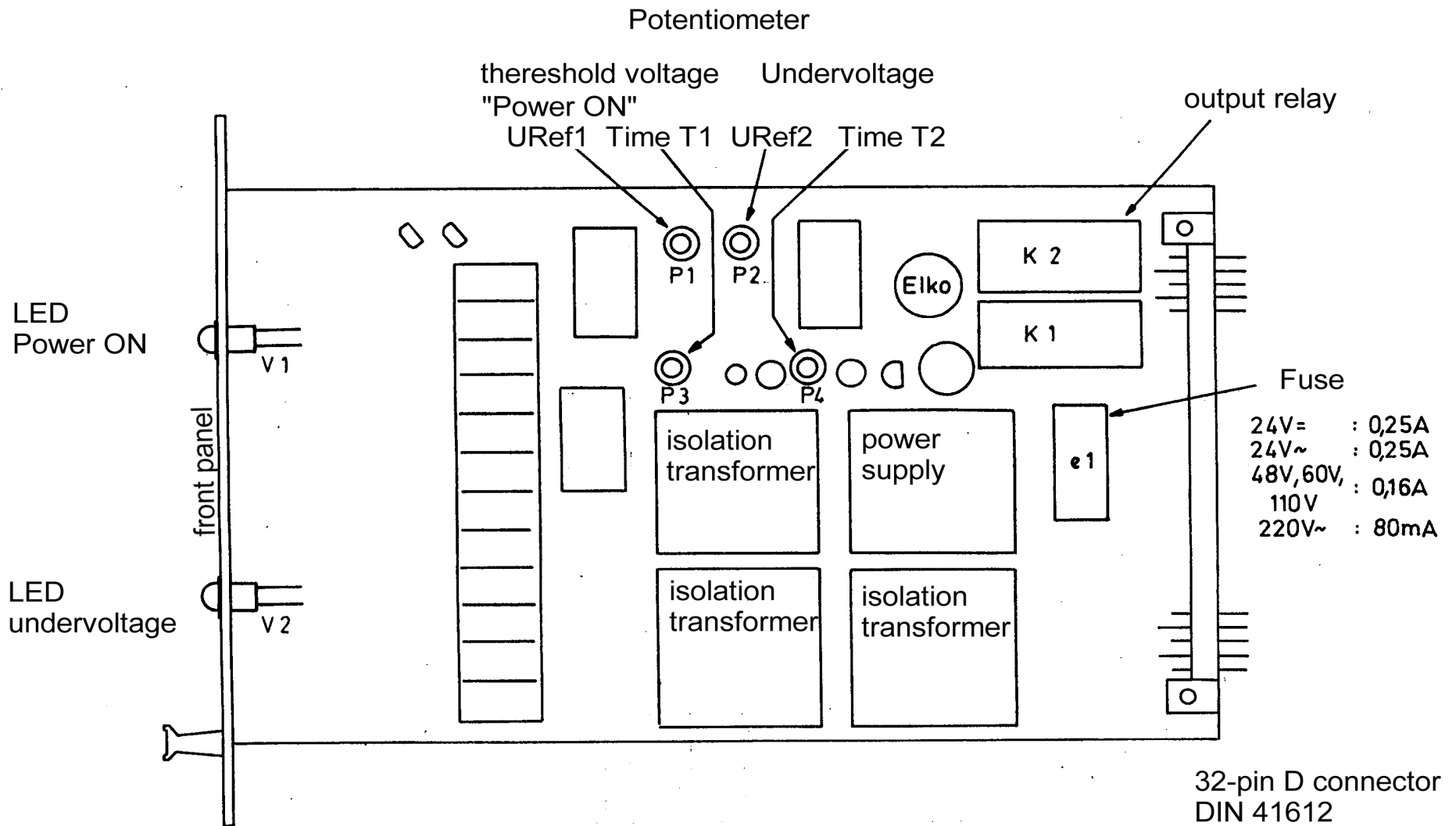

Abb.2 Position of the setting potentiometers EPW2Ü/4K

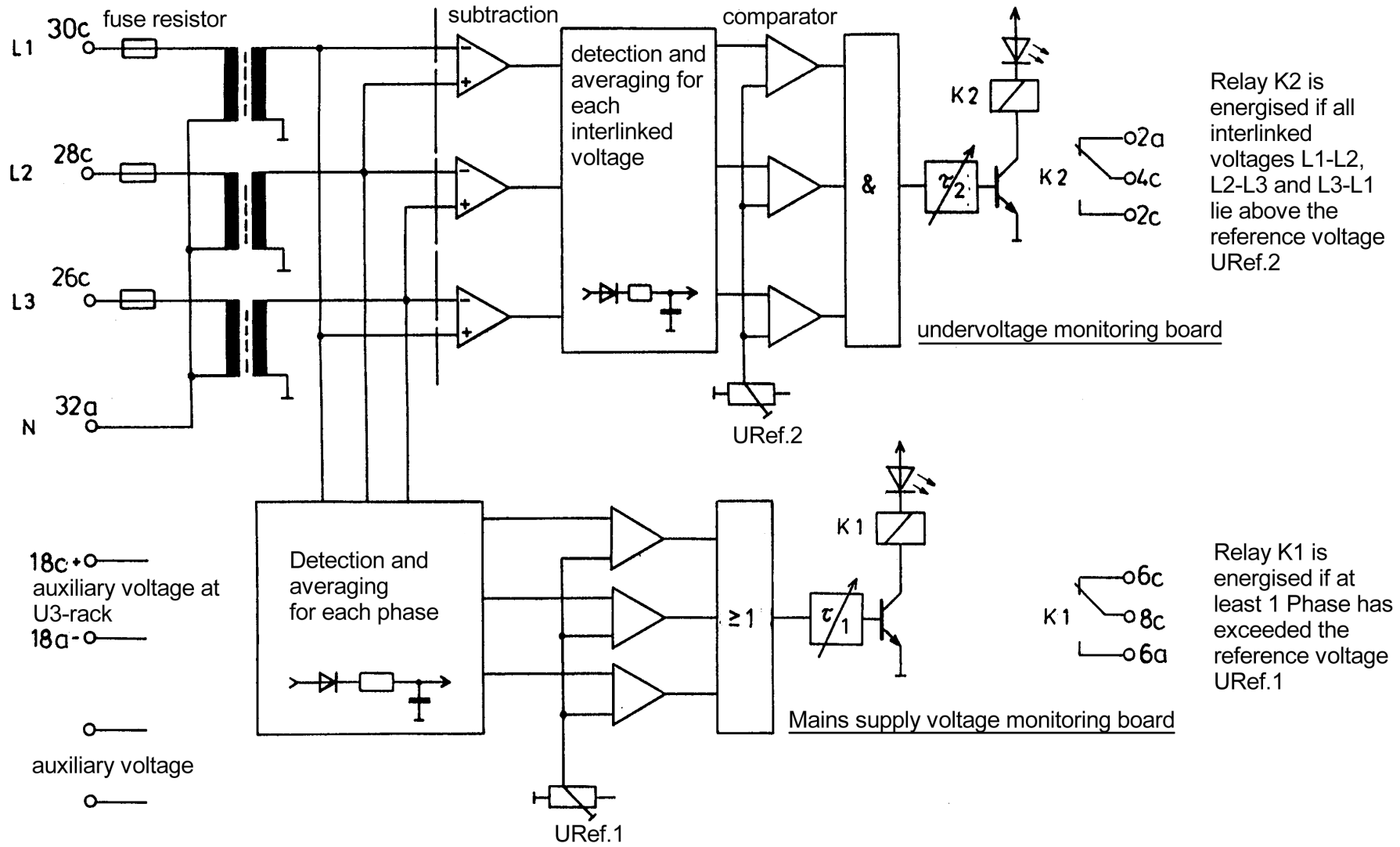

Abb.1 Schematic and wiring diagramm EPW 2Ü/4K | 32-pin D connector DIN 41612